

Arbeitsbühnen





Tecchio bis 22m



**Ruthmann- Steiger
bis 21m**

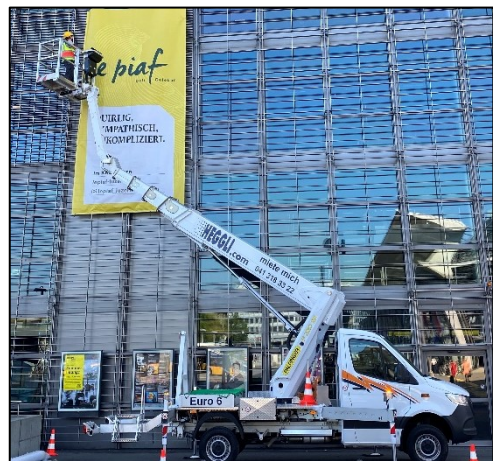

**Palfinger
bis 22m**

Tecchio bis 22m

Ohne Abstützung fahrbar

Arbeitskorb:
Nutzlast: 265 kg*
Länge: 1.40 m
Breite 0.70 m

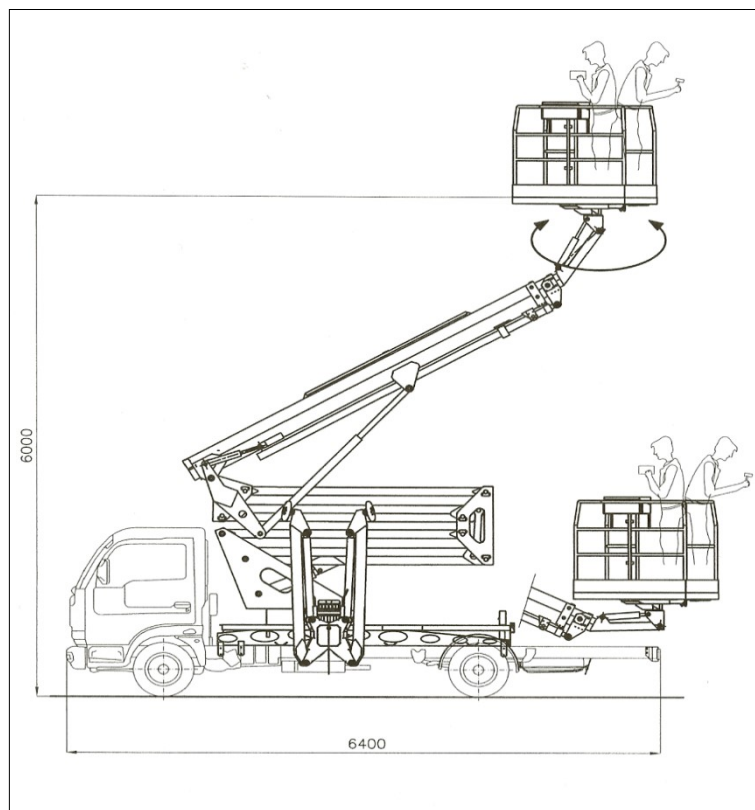
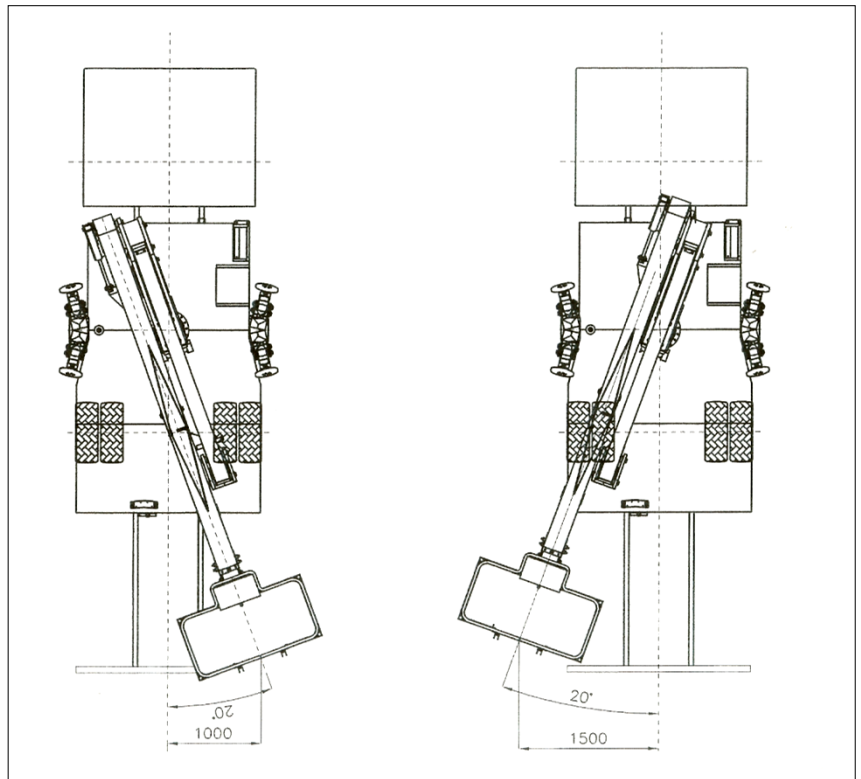

Tecchio bis 22m

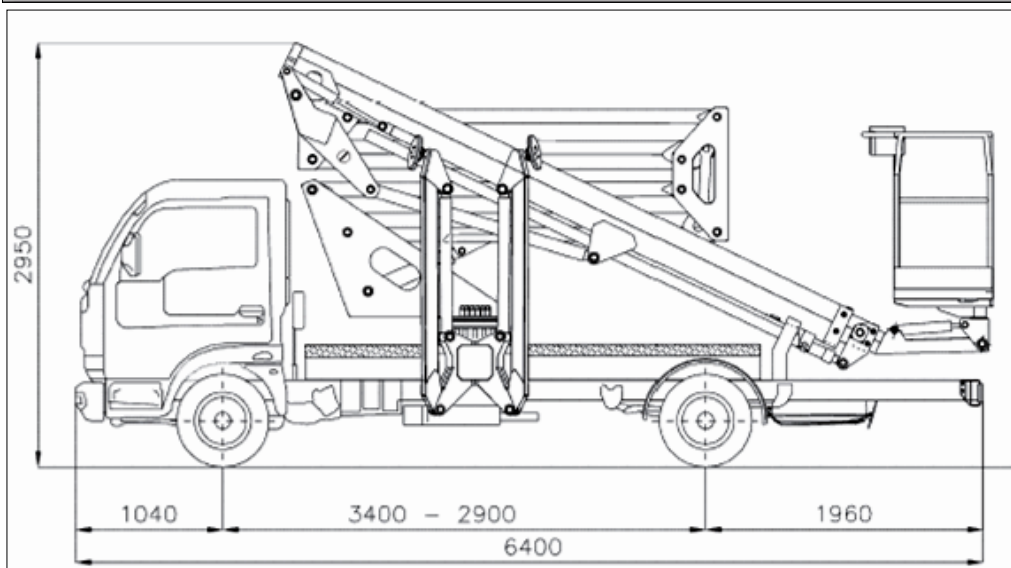
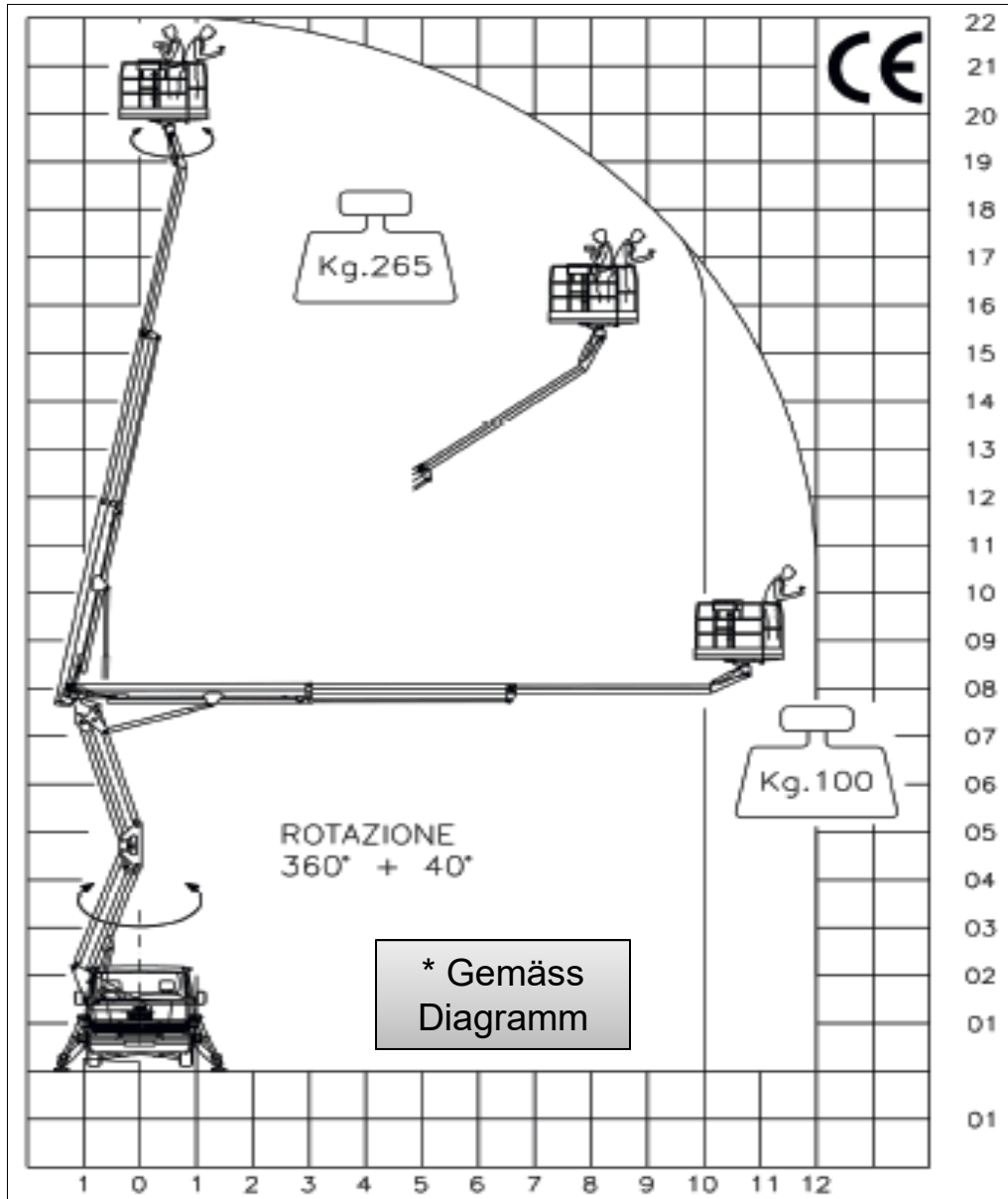

Ruthmann-Steiger bis 21m

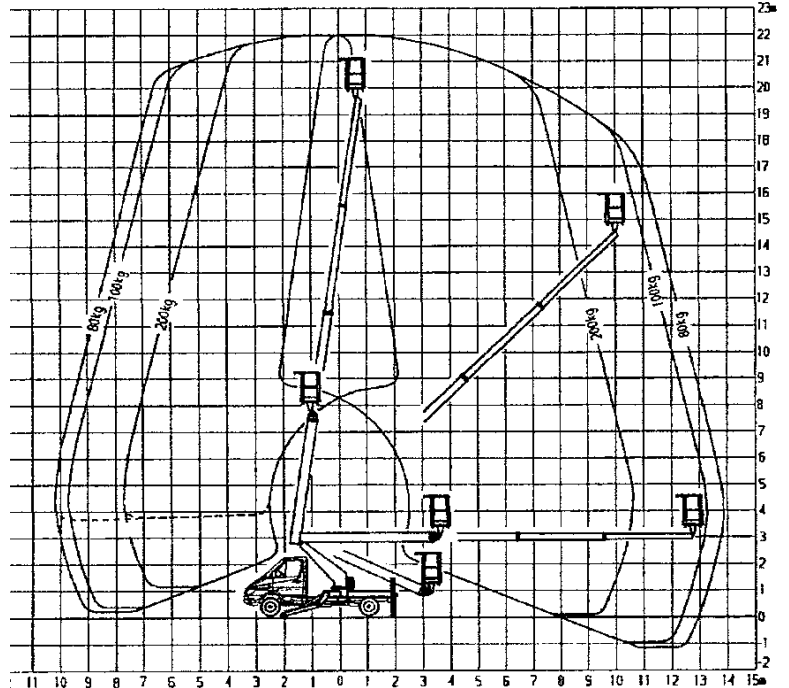
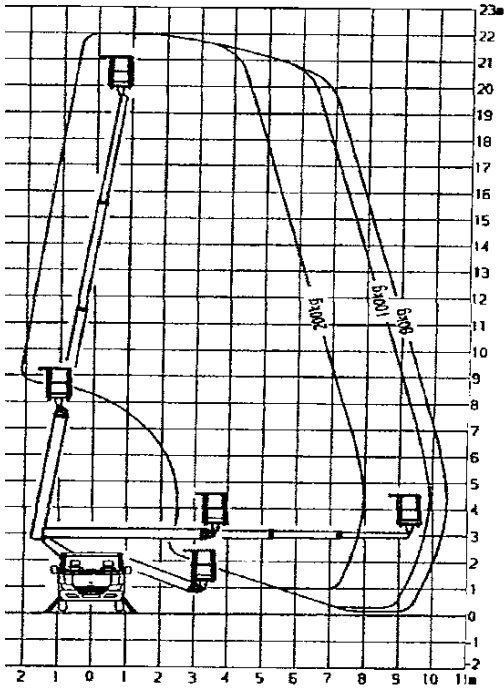

**Arbeitskorb:
Nutzlast: 200 kg*
Länge: 1.40 m
Breite: 0.70 m**

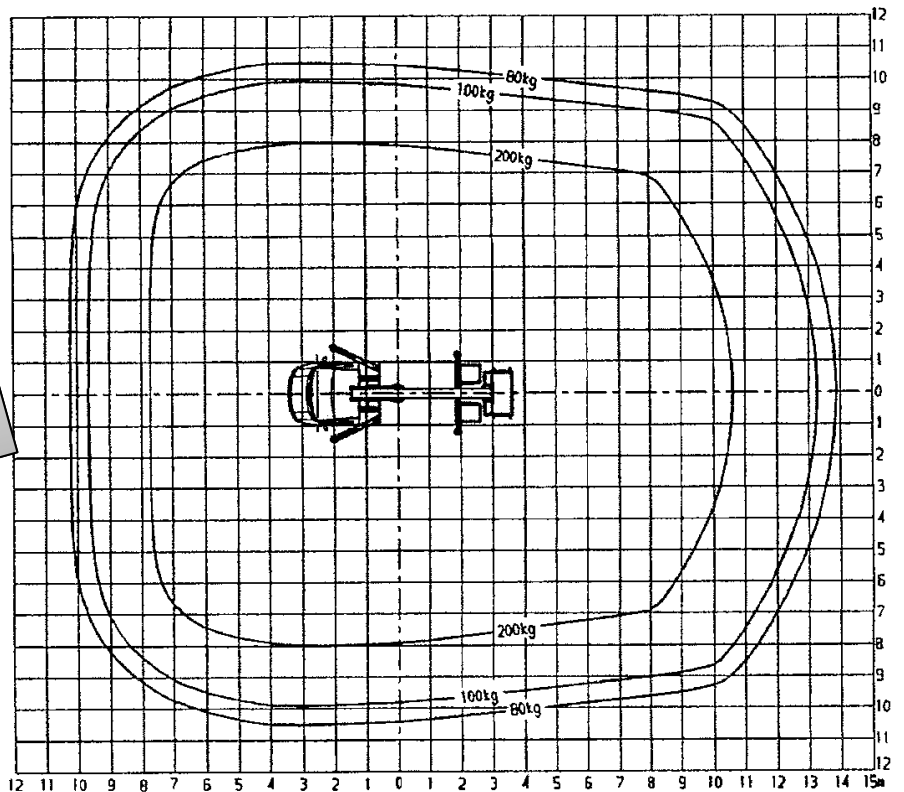

*** Gemäss Diagramm**

Arbeitskorb:
Nutzlast: 300 kg*
Länge: 1.40 m
Breite: 0.70 m



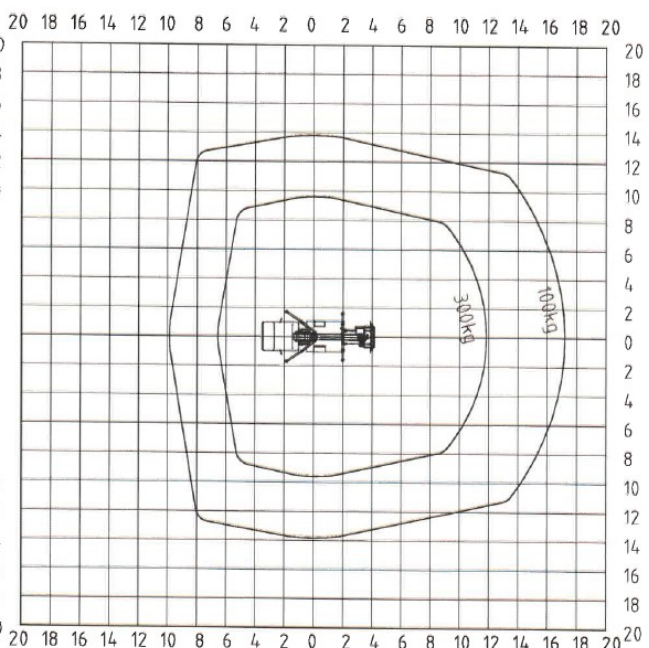
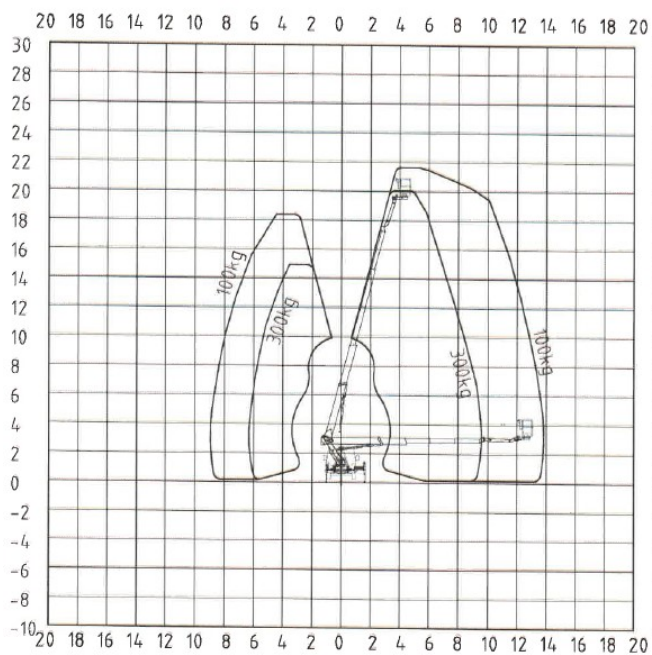
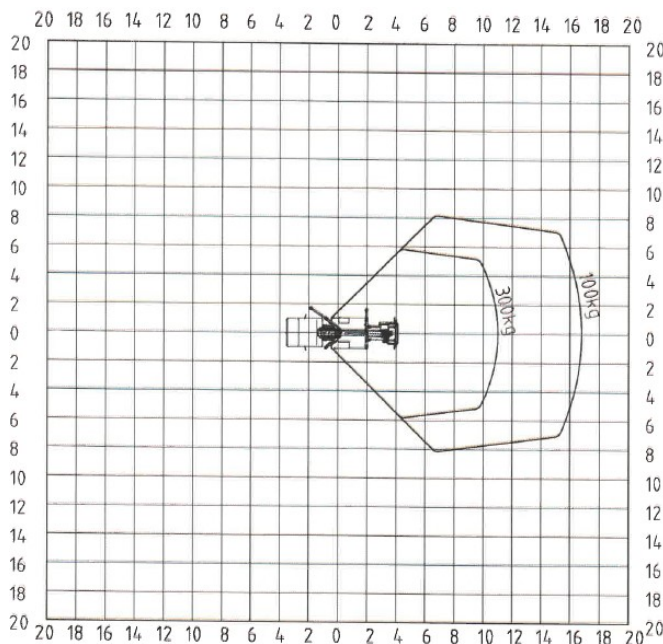
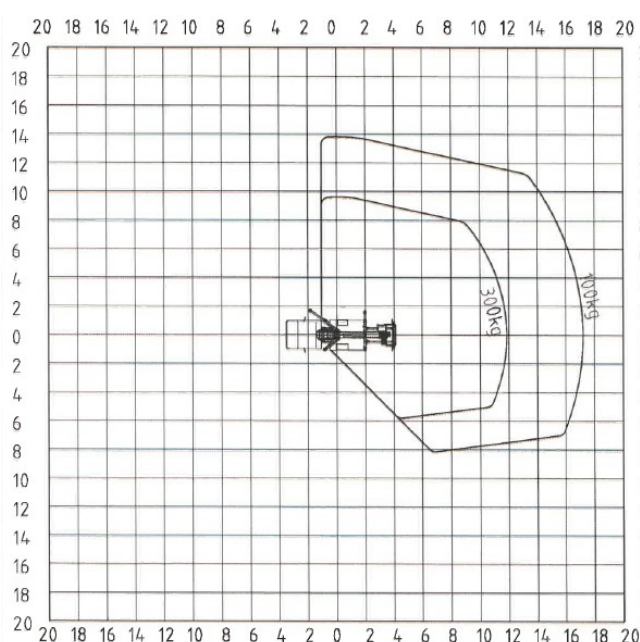







Palfinger bis 22m



*** Gemäss Diagramm**

Ruthmann Steiger 15m – 20m



RUTHMANNSTEIGER®		TBR 200	
	20,10 m		230 kg
	15,70 m		6,75 m
	450°		3,00 m
	105°		5°
	1,40 x 0,70 m		3.500 kg

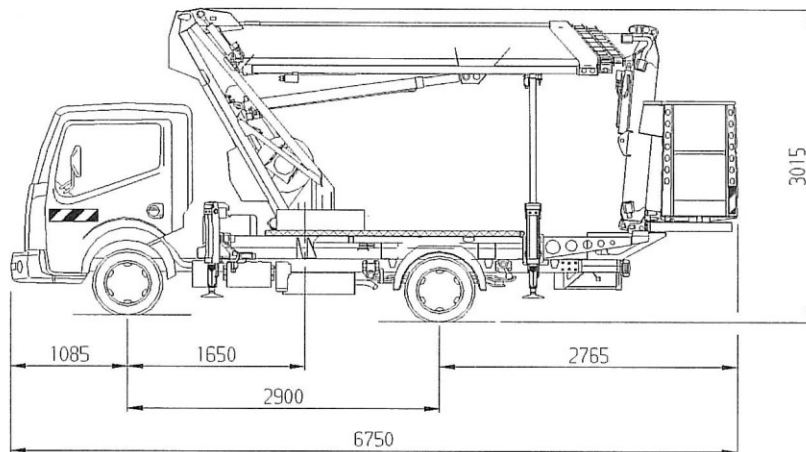

Alle Maße ca. Maße!
Änderungen vorbehalten!

<input checked="" type="checkbox"/>	<input checked="" type="checkbox"/>	<input checked="" type="checkbox"/>	RUTHMANN Anton Ruthmann GmbH & Co. KG D-48795 Gescher-Hoehoer	Datum	Name	Bemerkung	TBR 200	Zeichnungs-Nr.	Maßstab	Blatt
<input checked="" type="checkbox"/>	<input checked="" type="checkbox"/>	<input checked="" type="checkbox"/>		Bearb.	25.02.10	NL/Pg		Nissan Cabstar 35.11/2900	2_000_298_002	1:40
<input checked="" type="checkbox"/>	<input checked="" type="checkbox"/>	<input checked="" type="checkbox"/>	Gepr.	<input checked="" type="checkbox"/>	<input checked="" type="checkbox"/>					Blätter
Zust.	Datum	Name				Urspr.: 2_000_295_003		Ers.f.: <input checked="" type="checkbox"/>		Angebot: <input checked="" type="checkbox"/>

Ruthmann – Steiger 15m – 20m



Ruthmann 37m



Ruthmann 37m

Maße und Gewichte des Gesamtfahrzeuges

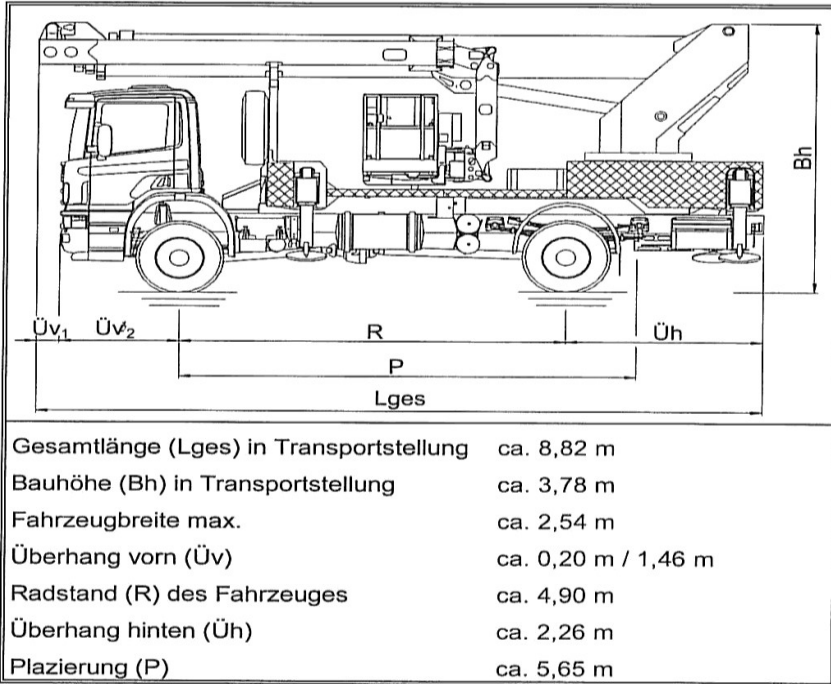

**Korblast:
500 kg*
Diagramm**

**Korbgrösse:
Länge 2.30 m – 3.60 m
(ausfahrbar)
Breite: 0.90 m**



Ruthmann 37m

* Gemäss Diagramm

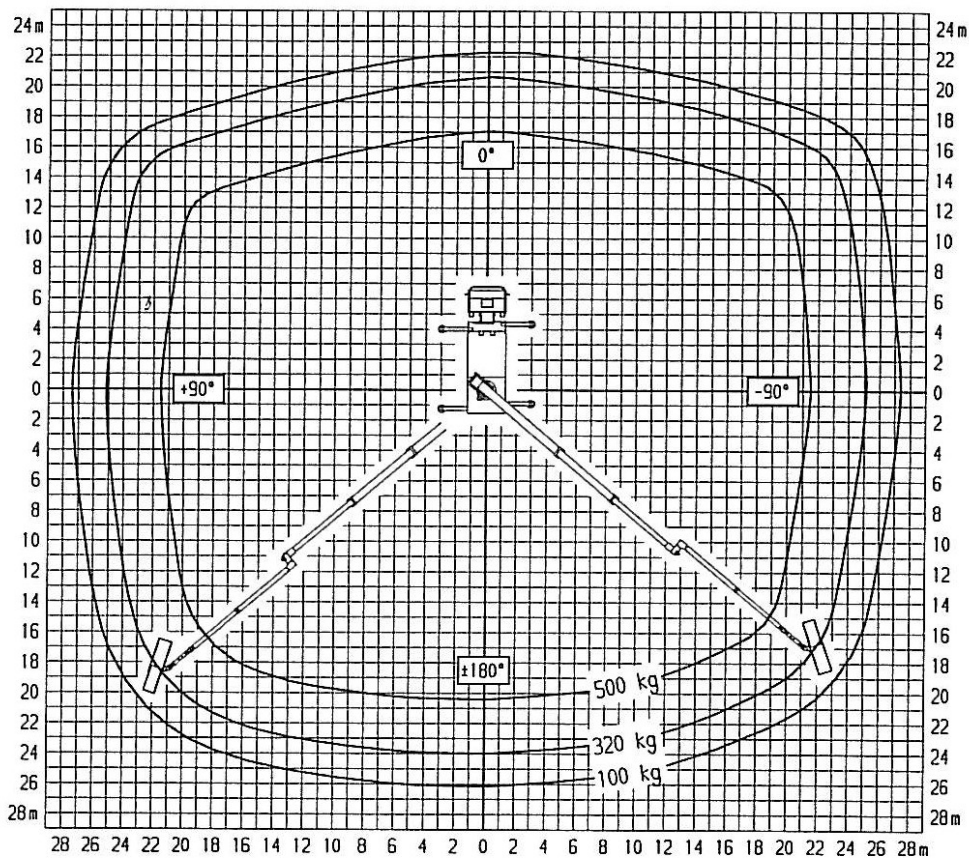
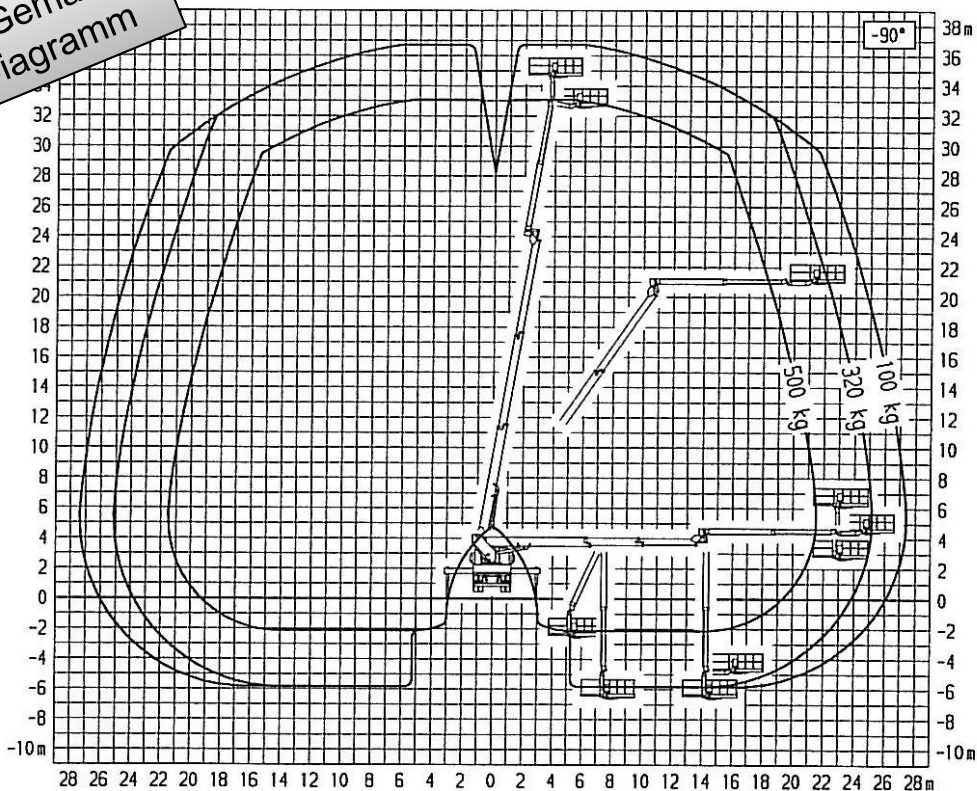

Hebebühne 51m



Arbeitskorb:
Nutzlast 200 kg
Länge 1.35 m
Breite: 0.60 m

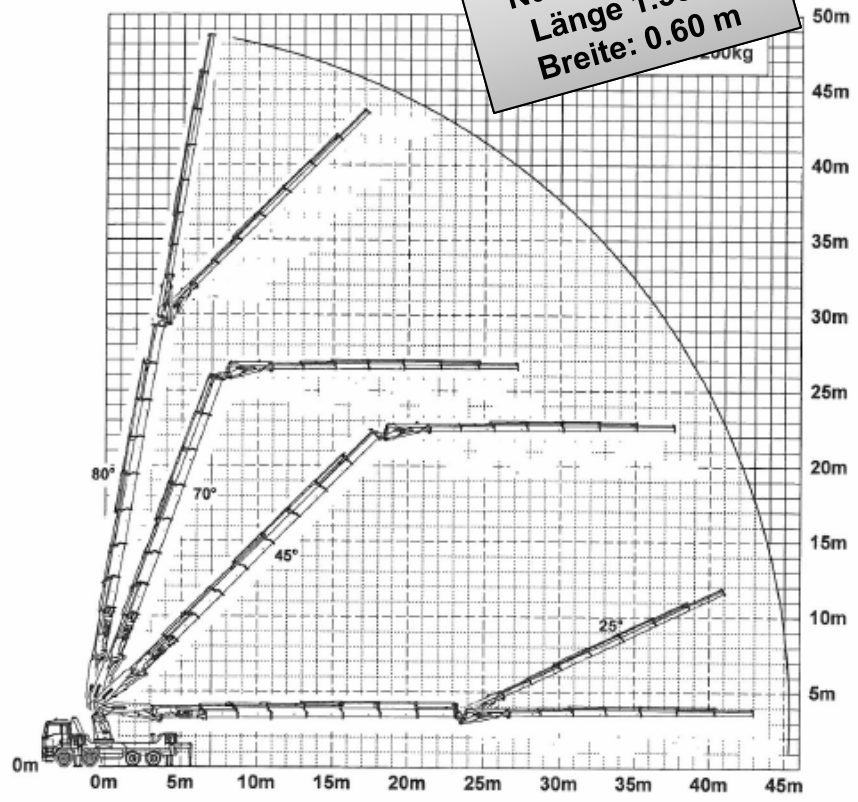

Palfinger 51m

